

# Know Your Insects

Revised by Carolyn Klass

\$1.50  
4-H Members' Guide  
M-6-1

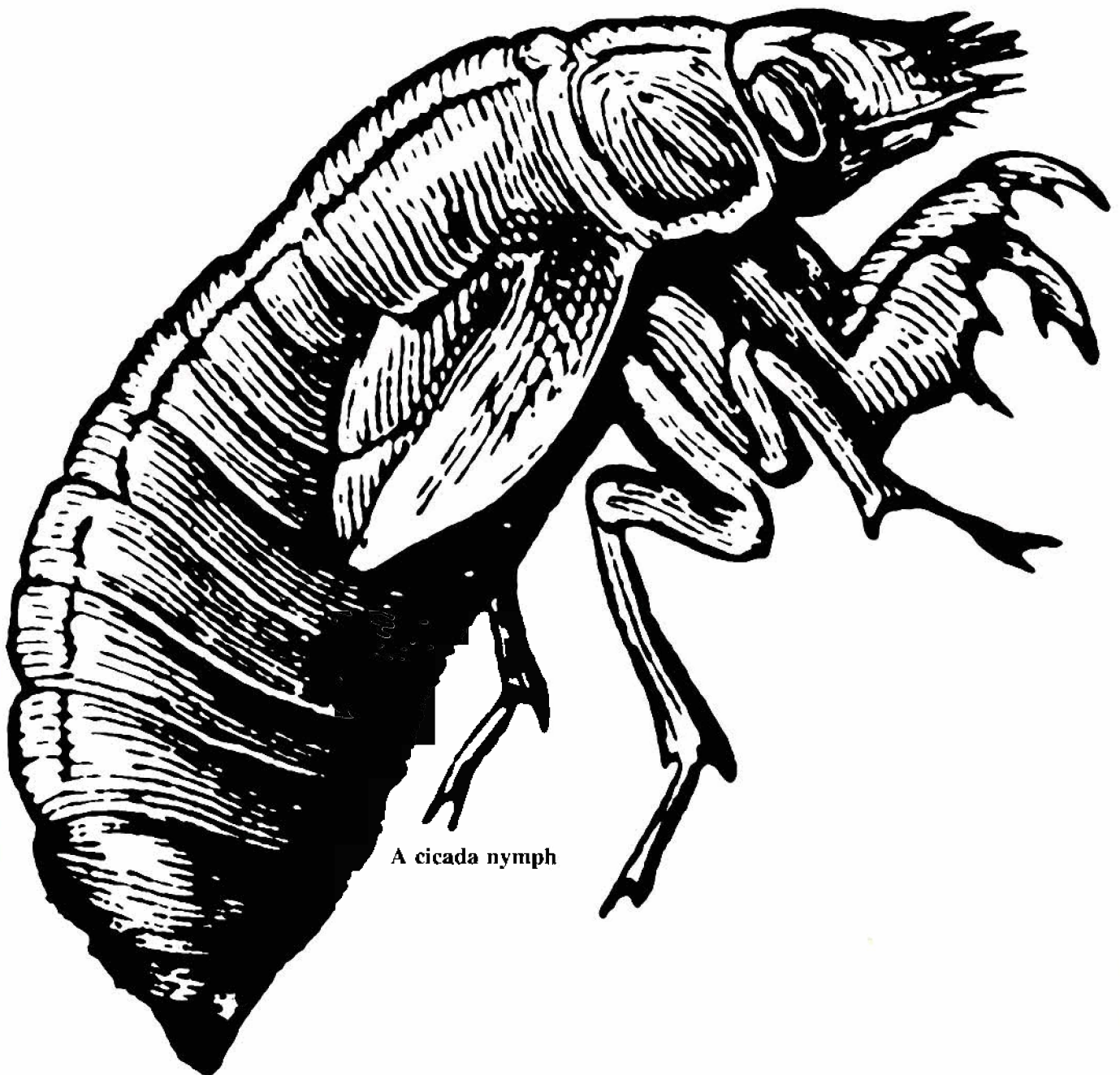

A cicada nymph

# Know Your Insects

## Contents

<b>General Instructions, Unit A</b>	1
Some Facts About Insects	1
Do Insects See, Feel, or Hear?	2
How Insects Grow	3
How to Make an Insect Collection	4
Equipment You Will Need	4
Insect Net	4
Killing Bottle	4
Display Case	5
Spreading Board	6
How, When, and Where to Collect	7
How to Mount and Preserve Specimens	8
Pinning Various Orders of Insects	9
Spreading the Wings of Various Orders	9
Identifying Specimens	10
Labeling Specimens	11
Preparing Insects for Display	12
Storing Your Collection	13
Demonstration Suggestions	14
References	14
<b>Know Your Insects — Unit B</b>	15
References	15
<b>Know Your Insects — Unit C</b>	16
Insect Rearing	16
Insect Control	16
Trapping Insects	17
Wing Collections in 2X2 Slide Mounts	17
Embedding Insects in Plastic	18
Photographing Insects	18
Correspondence Clubs	19
How to Ship Insects	20
References	21

Reference to commercial products is made with the understanding that no discrimination is intended and no endorsement is implied.

Carolyn Klass is an extension associate in the Department of Entomology, New York State College of Agriculture and Life Sciences, at Cornell University, Ithaca.

The information in this bulletin constitutes a revision of 4-H Members' Guide M-6-1, *Know Your Insects*, by W. T. Johnson, 1966. The author would like to thank Professor Verne N. Rockcastle, Department of Education, New York State College of Agriculture and Life Sciences at Cornell, for his ideas on an easy-to-construct spreading board, page 6; and a Chautauqua County 4-H Club for directions for making a display case, page 5.

Cover art from *Harter's Picture Archive (For Collage and Illustration)*. Jim Harter, ed. New York: Dover Publications, Inc., 1978.

# General Instructions:

## Unit A

The best way to get to know insects is to study them. How far you pursue the fascinating hobby of studying and collecting insects depends on your motivation. The project has no stopping place. You may start to study insects in grade school, continue through college, and make a career of it.

This guide gives only minimum instructions for beginning an entomology project. You will want to visit your local library or bookstore to find out more about insects and their ways.

In your first year you should become familiar with several of the common, showy insects in your community by studying them outdoors and by collecting, mounting, and identifying specimens. When you begin collecting, you may want to capture everything within reach, but soon you may want to concentrate on one or two groups. As you become familiar with the field of entomology, you will realize its magnitude and see the need to specialize.

In your first year, be a detective and watch insects go about their daily activities. Watch what and how a grasshopper or cricket eats. Do they have jaws and teeth, and if so do they work up and down or from side to side? Find out if insects have a way to protect themselves from danger (even from you when you get too close!). Do they work as a group or do they live by themselves? Watch some pest insects in your yard or garden for several days and see how they are controlled by natural means

such as birds, toads, and other insects.

Living insects are much more interesting than dead ones. Cultivate your ability to observe the behavior of these small animals.

Here are some other things you will do:

1. Keep an accurate, up-to-date record of your project and club activities. (Remember — successful completion of this project will place your work in competition with that of other club members for a trip to national club congress and a college scholarship.)
2. Volunteer to appear on the local 4-H Club program: whenever possible, give talks and demonstrations on entomology.
3. Exhibit your project at your school, county fair, and state exposition.

### Some Facts About Insects

An insect is an *animal* whose body has three distinct divisions — *head*, *thorax*, and *abdomen*. It has one pair of antennae (feelers) on the head. Attached to the thorax or mid-section are *three pairs of jointed legs* and usually one or two pairs of *wings*. The abdomen is the largest body division. A few insects such as earwigs and mayflies have long appendages at the end of the abdomen. On the sides of the body are small openings called *spiracles* through which the insect breathes. These openings are easily seen on the abdomens of grasshoppers and caterpillars (Figure 1).

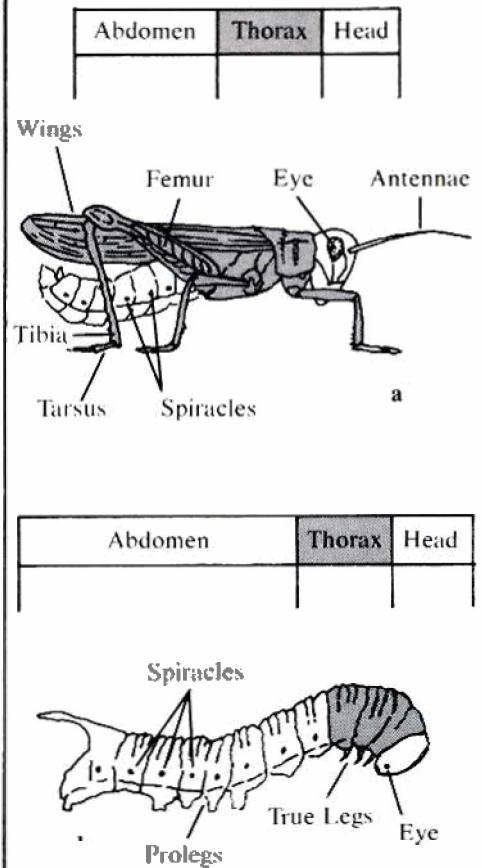
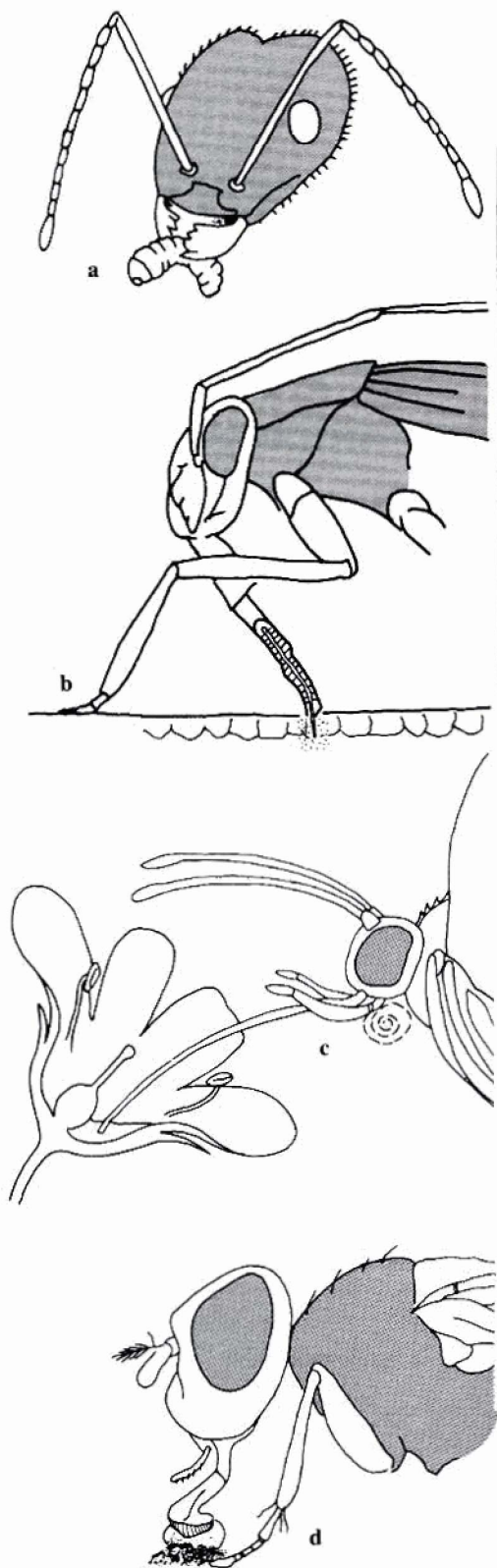

Figure 1. (a) Adult grasshopper. Some features of insects that make them different from all other kinds of animals. (b) Larva or caterpillar stage.



**Figure 2.** Types of insect mouth parts. (a) chewing mouth parts showing mandibles; (b) piercing, sucking mouth parts; (c) siphoning mouth tube of butterflies (proboscis); (d) sponging mouth parts of certain kinds of flies (*Diptera*).

Insects have no bones, but are covered with a hard shell called an *exoskeleton*. This shell is lighter and stronger than bone and serves as a point of attachment for muscles. It also serves as a protective armor in many species, protecting the internal organs.

Insects feed on plants and other animals, living or dead. Because they have such diverse food requirements, they have different kinds of mouth parts. Food is taken into their bodies in either liquid or solid forms. Mouth parts for piercing, siphoning, and sponging provide the insect with food in liquid form, whereas those insects with grinding teeth (called *mandibles*) take solid food.

The type of mouth parts is an important characteristic used in identifying insects. Mouths are small, and it is often necessary to examine them with a hand lens or magnifying glass to determine their type (Figure 2).

The legs of adult insects are easy to distinguish; each one has five movable parts. Locomotion is the primary function of legs, but they are built for different types of movement — walking, running, leaping, swimming, grasping, and digging. In addition to the thoracic legs, caterpillars have fleshy, non-jointed *prolegs* on the abdomen that have primarily a clinging function. Some immature insects (flies and certain beetles) do not have legs.

Some insects are wingless. Those with wings have either one or two pairs. Most wings have thickened lines that run from the base to the tip — these are called *veins*. In a given species the pattern of veins, called *venation*, is always the same and thus helps to distinguish that species. There are several types of wings: the *membranous wings* of flies resemble pieces of cellophane, the hard *leathery wings* (elytra) of beetles; the wings of stink bugs and assassin bugs with membranous tips and hard and leathery bases; the *scaly and hairy wings* of moths and caddisflies, and the *feathery wings* of thrips, and the *parchment wings* of grasshoppers, crickets, mantids, and others of the

order Orthoptera (Figure 3).

**Do Insects See, Feel, or Hear?** Insects apparently have all the senses of higher animals. Some of their organs of perception are much more sensitive than those of people. Insects are able to perceive sounds within certain ranges, and a few have "ears," usually on their legs or thorax. They have two organs of sight, *compound eyes* and simple eyes called *ocelli* (o-cell-i) (singular *ocellus*). The compound eyes of adult insects are large. They are immovable and consist of hundreds of lens-retina-nerve units, each capable of producing an image. Eyes are always located on the head (Figure 4). The senses of smell and taste are not concentrated in single organs; tastes and smells may be perceived through sensory hairs on the *tarsi* (feet), *palpi* (part of mouth structure), *antennae*, or elsewhere. Some insects can detect odors for nearly a mile, and bees can distinguish between sugar and saccharin.

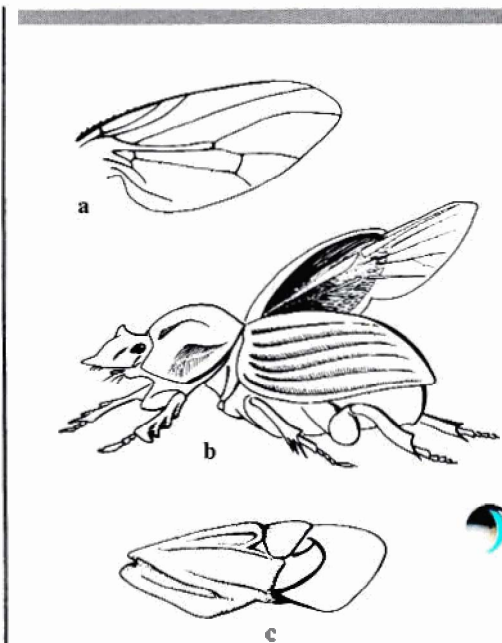
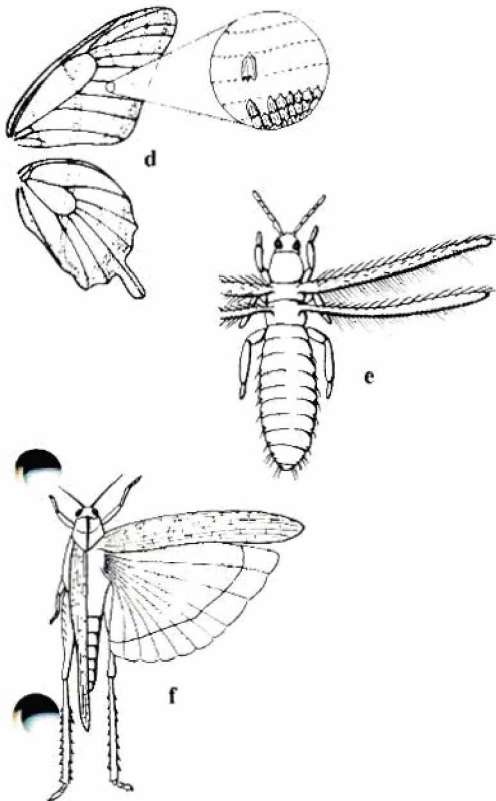

**Figure 3.** Types of insect wings. (a) Membranous wing of a fly. (b) Leathery and membranous wing of *Coleoptera*. (c) Intermediate wing of *Hemiptera* (leathery base, membranous tip). (d) Scaly wing of *Lepidoptera*. (e) Feathery wings of thrips, and (f) Parchment wings of grasshoppers.

Insects have all the internal systems of higher animals including digestive, respiratory, circulatory, nervous, muscular, reproductive, and excretory systems. The muscular system is highly developed, and much has been written about their extraordinary strength. According to some investigators the average insect can pull over 20 times its weight. Their muscles are capable of rapid reactions, contracting and relaxing with great speed and endurance. The working wing muscles of a housefly, for example, can cause its wings to beat at the rate of 330 strokes per second. The number of muscles in an insect is also remarkable. Certain caterpillars have over 4,000 muscles as compared to a person's 792.

Additional reading from the references will reveal many astounding facts about the other internal systems of insects.

**How Insects Grow.** Insects develop from eggs. The eggs may be laid in selected places as exemplified by



moths, or the eggs may hatch within the body of the female and be born as living young, as with certain aphids or flies. Eggs are small and seldom noticed except when laid in masses or groups that are conspicuous. In exceptional cases a single female may lay only one egg, but at the other extreme, a million or more may be deposited. The average number for all insects is probably over 100.

An insect grows by a process known as *metamorphosis* (met-a-more-fo-sis) or change in form. When it emerges from its egg looking like a miniature of its parents, it develops by *slight or incomplete metamorphosis* (Figure 5); if it is quite different in form from its parents, its development is called *complete metamorphosis* (Figure 6). Complete metamorphosis is a complicated biological wonder, and the insect with this growth process develops in four completely different stages — egg, larva, pupa, and adult.

All growth in size occurs during the immature stage. Before an insect can increase in size, it must cast off its old exoskeleton by a molting or shedding called *ecdysis* (ek-di-sis). To accomplish this, the immature insect forces its exoskeleton to split along the upper surface of the head and thorax, then crawls out through this slit. Before its new skeleton hardens,

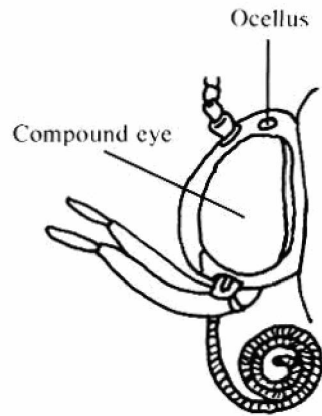

Figure 4. Insect head showing large compound eye and simple eye (ocellus).

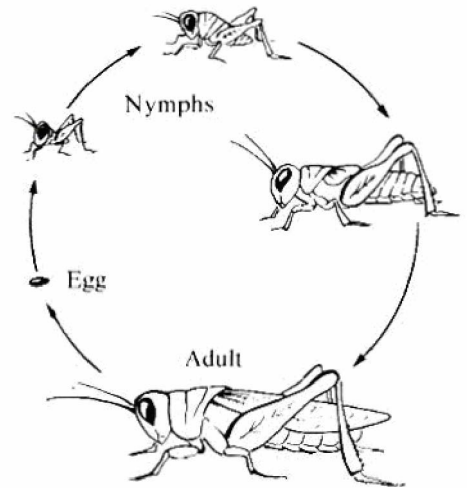

Figure 5. Simple metamorphosis.

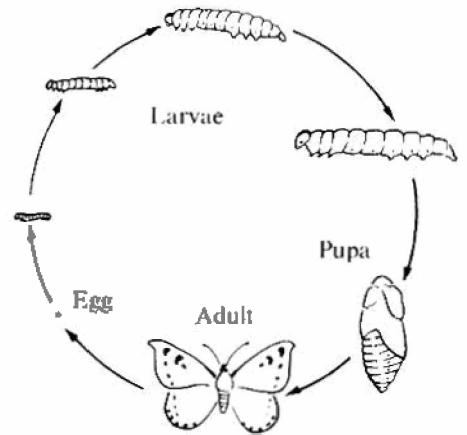

Figure 6. Complete metamorphosis.

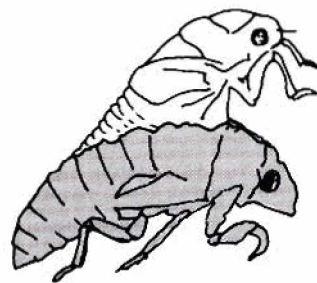

Figure 7. A molting insect. The old exoskeleton splits first at the back of the head and along the mid-line down the back. The insect works out its head first, then the thorax and abdomen.

the insect increases in size (Figure 7). The periods between molts are called *instars*. Thus, a second instar caterpillar is in its second growth interval. Insect growth is not gradual as in other animals but is a series of several jumps or stages of growth. When it reaches the adult stage there will be no further molts. A small fly or moth is not a "baby" but a full-grown adult.

### How To Make An Insect Collection

#### Equipment You Will Need

**Insect Net.** An insect net can be made easily and cheaply (Figure 8). This is an aerial or butterfly net and is most useful for catching insects that are flying. The nets are easily torn and for this reason should be kept away from thorny bushes and trees. There are several other kinds of nets used primarily for sweeping through vegetation and for catching aquatic insects.

#### Materials Needed

- Small wooden handle, about 3' (1 meter) long. Either a broom handle or a dowel are suitable.
- 4' (122 cm) of heavy, stiff wire about 3/8" (.32 cm) in diameter for hoop.
- Mosquito netting or heavier material (marquisette, batiste, or scrim), 3' x 5' (91.4 cm x 152.4 cm).
- Cord, wire, or tape for attaching

the hoop to the handle (about 5' (152 cm)).

- Saw, hammer, brace, small bit, narrow wood chisel.

Optional — heavy band of muslin or canvas to cover the hoop wire. Sew muslin to net material.

#### Procedure (see illustrations)

1. Bend wire into shape (8a).
2. Bore hole and cut grooves in broom handle (8b).
3. Make pattern, cut cloth, make casing (8c), and sew net seam — leave 3" unsewed (8d) at wide end to aid in step 4.
4. Slip bag on wire; sew remaining seam by hand.
5. Attach wire to handle and wrap with cord, wire, or tape (8e).

#### Killing Bottle

##### Materials Needed

- Jar — a pint jar with a tight-fitting lid or other of similar size and type.
- Tape — electricians' tape or masking tape.
- Cardboard (heavy).
- Shredded paper towel, newspaper, felt, or cotton; piece of sponge or plaster of Paris.
- Killing agent: small bottle of ethyl-acetate, rubbing alcohol, or ammonia; or a one-inch piece of Vapona impregnated strip (No-Pest Strip).

#### Procedure

For fluid killing agents (Figure 9a)

1. Put shredded material into the jar, tamp down to about 1" (2.5 cm) thick (a pencil eraser end works well to tamp the paper); or put a layer of plaster of Paris 1/2" — 3/4" (1 — 2 cm) deep in bottom of jar. Let plaster of Paris dry thoroughly (a few days with jar open) before use.
2. Cut a cardboard disk to fit the inside of the jar. This will be used to hold shredded paper down and to provide a dry surface when the insects are put into the jar.
3. Wrap the outside bottom 1" (2.5 cm) or so of the jar with tape. This makes the jar easier to hold and keeps it from shattering if dropped.
4. Hold the jar at a slant and pour some of the killing fluid down the inside so it soaks into the shredded

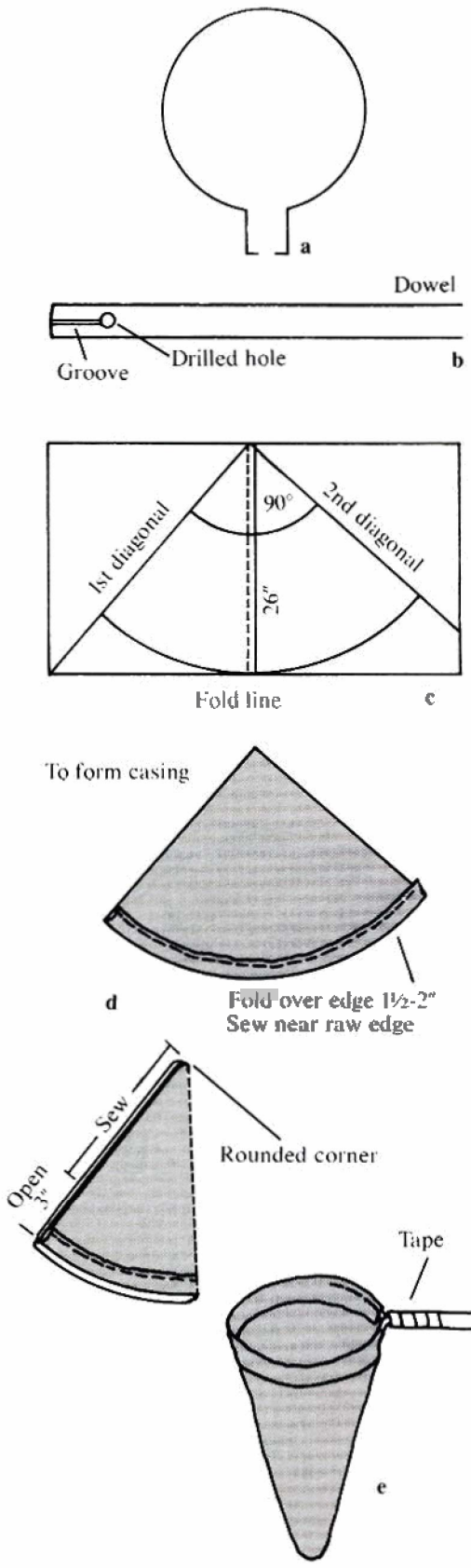

Figure 8. Collecting net. (a) Bend coat hanger or wire. (b) Bore hole and cut grooves. (c) Make pattern. (d) Cut cloth, make casing, sew seam leaving 3" on lower edge. (e) Attach net to handle.

paper or plaster of Paris. Insert the cardboard disk.

5. Label the jar **Poison** and be sure that people understand they should not hold the jar open any longer than necessary and should not breathe the fumes. Store the jar in a safe place where it will not easily fall over or be disturbed when not in use.

*For Vapona Strip (Figure 9b)*

1. Put the one-inch strip in the bottom of the jar. (A sharp knife or heavy shears work best to cut the strip.) Replace unused portion in its foil wrapper and reseal. A drop of glue in the bottom of the jar will hold strip in place. The piece in the jar should be effective for 1 – 2 months depending on use. Wash hands thoroughly after handling the strips.

2. Same as no. 2 p. 4 – in this case insert a cardboard disk or piece of screening.

3. Same as no. 3 p. 4.

4. Follow step no. 5 above.

All insect-killing fluids are moderately toxic. When using them avoid breathing the fumes, and if the fluid should get on your skin, wash it off immediately. Never leave the killing fluid or charged killing bottle where a younger brother or sister can reach

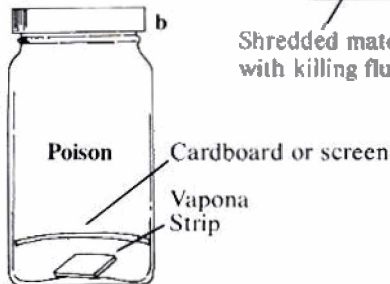
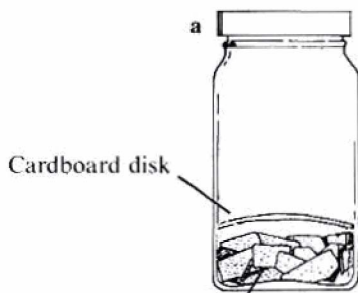

Figure 9. Insect killing bottle. Make two, one for scaly-winged insects and one for all others. (a) Fluid killing agent, (b) Vapona strip.

them. Ethyl acetate, an ingredient of some nail polish removers, is used for killing because it is relatively non-toxic to people and leaves the insect flexible for mounting. It has two disadvantages: it is usually not available locally and must be ordered from chemical and biological supply houses; it is flammable and must be handled with the same care you would use with charcoal lighter.

Ammonia is also sometimes used, but it will discolor some specimens, especially some of the butterflies.

After the insect is killed, it is ready to mount. Always have two killing bottles, one for moths and butterflies and another for all other insects. The scales of moth and butterfly wings come off easily and spoil specimens of other orders. Wipe out the bottles occasionally to remove scales and debris.

**Display Case (Figure 10)**

Note: All dimensions drawn for use of 3/4" (1.9 cm) stock.

*Materials Needed*

- 2 pieces of wood 3/4" x 2 1/2" x 20" (1.9 cm x 6.35 cm x 50.8 cm).
- 2 pieces of wood 3/4" x 2 1/2" x 16" (1.9 cm x 6.35 cm x 40.64 cm).
- 2 pieces of wood molding 3/4" x 20" (1.9 cm x 50.8 cm).
- 2 pieces of wood molding 3/4" x 17 1/2" (1.9 cm x 44.45 cm).
- 1 piece masonite 1/8" x 17 1/2" x 20" (.3 cm x 44.45 cm x 50.8 cm).
- 1 piece of double strength glass, clear plastic or Plexiglass 16 3/4" x 19 1/4" (42.5 cm x 49 cm).
- Celotex ceiling tiles or 1/2" (1 cm) plastic foam or corksheets enough to equal 16" x 18 1/2" (40.64 x 46.99 cm).
- 1" brads (nails).

*Procedures (Figure 10a)*

1. Obtain materials and cut wood to stated sizes.
2. Nail and glue sides together (make sure it is square) (Figure 10b).
3. Nail and glue Masonite bottom to box.
4. Nail and glue molding except one 17 1/2" (44.45 cm) piece (X) (Figure 10c). Nail this piece using 2, possibly 3 nails. After box dries, pull molding X out and cut off end on nails (Be

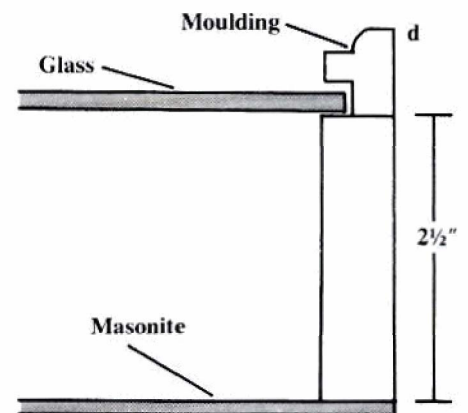
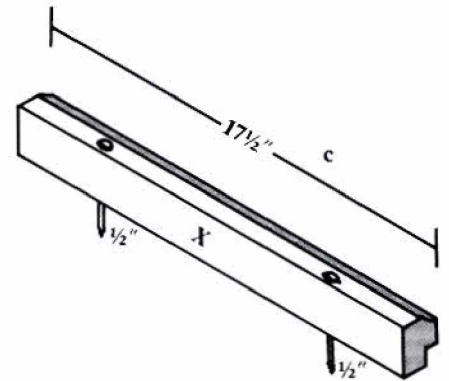
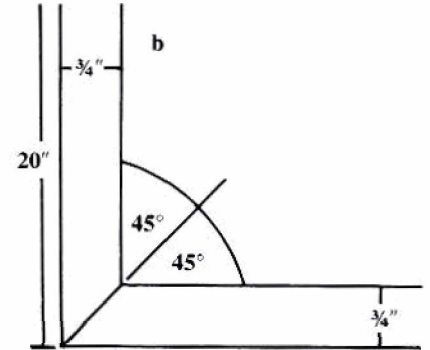
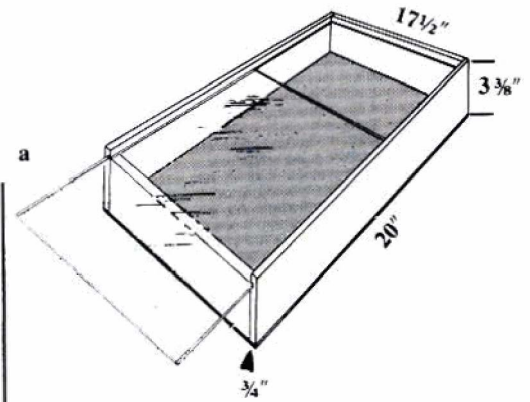

Figure 10. (a) A standard exhibit case for pinned insects. (b) Assemble properly. (c) Cut so nails on molding protrude only about half an inch. (d) glass should slide freely.

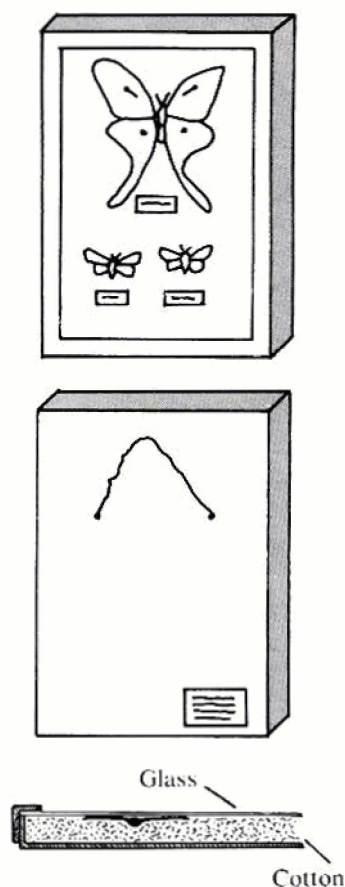

Figure 11. The Riker mount with construction details (redrawn after Borror and DeLong).

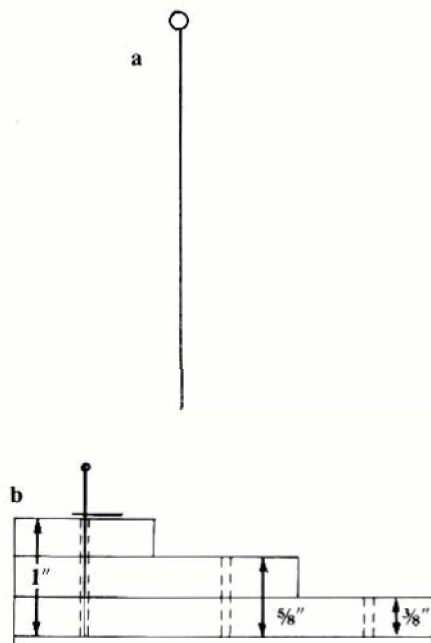

Figure 12. (a) The standard insect pin is made of blue steel and has a brass head. (b) A step pinning block.

sure to drive nails straight.) Varnish or paint box.

5. Cut and glue ceiling blocks to fill bottom of box as pinning medium. Cover this with sheet of construction paper.

6. Have glass cut to slide freely in and out (Figure 10d). When glass is in place and exhibit ready, replace side X into original nail holes.

A Riker mount (Figure 11), a cotton-filled cardboard box with most of the lid removed and replaced with glass, is another container that can be used to display insects. The specimens are held in place on the cotton by pressure from the glass. When the insects to be mounted are large, some of the cotton padding must be removed to provide space for their bodies. Riker mounts may be of almost any size, but a convenient standard one is 8" x 12" (20.3 cm x 30.5 cm) and 3/4" (1.9 cm) deep. They can be purchased from biological supply houses, or can be made. However, if the club member makes his or her own, it is recommended that he or she buy the glass pre-cut. Construction details can be studied in the illustration. Riker mounts are particularly useful for life-cycle collections or for displays of unusual specimens to hang on the walls of your room at home or school.

Insect pins (Figure 12a), which are essential for making a permanent insect collection, should be purchased from biological supply companies. (Common sewing pins rust quickly and ruin the specimens. They are also too large in diameter and not tall enough to allow you to fit the labels on.) The No. 2 insect pin is recommended for first- and second-year collections.

Pinning blocks can be made or bought. There are various types; a common one (Figure 12b) consists of a block of wood in which are drilled three small holes of different depths, usually 3/8", 5/8", and 1" (.9 cm, 1.6 cm, and 2.54 cm) deep respectively. Plastic foam also may be used if cut to the proper dimensions. The holes are used to adjust the placing of the in-

sect and the labels on the pin.

### Spreading Board

A spreading board is a device for holding a dead insect in position while its wings are being adjusted for display and are drying. Instructions follow for a simple cardboard one (Figure 13a) and also a more permanent wooden spreading board (Figure 14).

### A Simple Cardboard Spreading Board

#### Materials Needed

- Sheet of corrugated cardboard 11" x 17" (28 cm x 43 cm).
- Ruler, pencil, sharp knife, glue.
- Four corks or small pieces of wood about 3/4" (2 cm) high.
- Four paper fasteners.

#### Procedure

1. Mark long edge of the cardboard at 1", 4 1/4", 5 1/4", 11 7/8", 12 7/8", and 16" (2.54 cm, 10.5 cm, 13 cm, 32.7 cm, and 40.6 cm)
2. Repeat on opposite long edge of cardboard and connect the marks by drawing lines (Figure 13b).
3. Cut along these lines with a sharp knife, being careful to cut through only the top layer and the corrugated layer of the cardboard.
4. Turn the cardboard over and fold along cut lines as shown in the illustration. Leave a groove in the center for the insect's body.
5. Insert fasteners to hold spreading board together. Glue corks at the corners for legs.

### A Wooden Spreading Board

#### Materials Needed

- Two pieces of softwood for strips 1/4" x 2" x 12" (.6 cm x 5 cm x 30.5 cm).
- Two pieces of softwood for blocks, 1/2" x 1" x 4 1/2" (1.3 cm x 2.54 cm x 11.4 cm).
- One piece of plywood for bottom, 1/4" x 4 1/2" x 12" (.6 cm x 11.4 cm x 30.5 cm).
- One piece of cork or balsa wood, 1/4" x 1" x 12" (.6 cm x 2.54 cm x 30.5 cm).
- Glue, hammer, and small nails.

#### Procedure

- Assemble as illustrated (Figure 14).
1. Nail wooden strips on blocks,



- leaving them about  $\frac{1}{4}$ " (.6 cm) apart.
2. Nail cork strip beneath groove.
  3. Glue plywood bottom on blocks.

Spreading boards also may be made from plastic foam such as the styrofoam that florists use. (Since plastic foam is often used as packing materials for appliances, merchants sometimes give it away.) Smooth plastic is always best. Cut a slot in the foam (as in the wooden spreading board) or a series of oblong or canoe-shaped holes sized to accommodate the bodies of large, medium-size, and small insects.

If insects become too hard and brittle to pin or manipulate, they can be placed in a relaxing chamber for one or two days and be made soft and pliable again. To make this chamber, get a large-mouth jar or metal container that can be made airtight. In the bottom, place an inch of clean sand saturated with water to which a few drops of carbolic acid (Lysol) have been added to prevent mold. Put the specimens in an open shallow container, and set this container in the sand. The insects should not touch the sand. Close the lid tightly. Check the specimens after one day, and if they are soft enough to handle, mount them immediately. Specimens may be ruined if left in the chamber too long.

Remember, it is always best to pin specimens within a few hours after they are collected.

Forceps have many uses — to pick up dead insects, to aid in spreading wings, to remove a pin from an insect, to force a pin into an exhibit case, and the like. A hand lens is often necessary to determine the number of wings, the kind of mouth parts, the number of tarsal (foot) segments and to find many small structures on the insect's body (Figure 15).

Consult your club leader or agent for the addresses of biological supply houses where entomological equipment may be purchased.

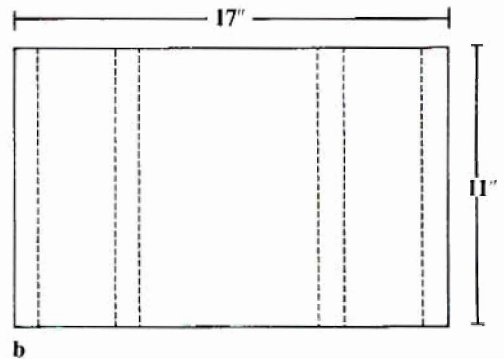
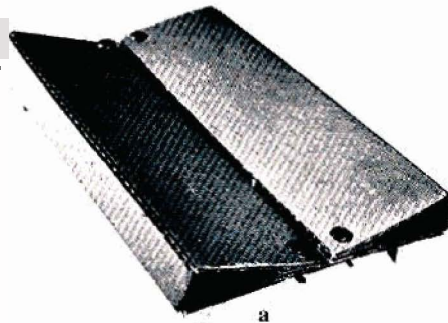

Figure 13. (a) Simple spreading board. (b) Diagram for construction.

### How, When, and Where to Collect

There are nearly one million insect species known in the world today — more than all other kinds of animals and all the kinds of plants put together (Figure 16). A good collector can locate insects at almost any time of the year. Winter insect stages are interesting to collect; it is a good time to look for moth cocoons attached to twigs. Some species appear only during cool seasons. In the middle of winter certain stoneflies can be found sunning themselves on exposed rocks near streams. Mosquitoes and gnat-like insects may be found at similar locations. On warm winter evenings moths and other insects may be attracted to light. Some household pests may be present year-round.

Insects are most abundant in fields, woods, and streams during late spring, summer, and early fall. Some are easily caught, and others almost defy catching, adding wit and cunningness to the attributes needed by the collector. But in any case, the collector, unless he or she uses a trapping device, must go to the insect. Insects are wild animals, just as wild as lions or zebras in Africa, and the person who goes collecting can think of himself or herself as going on a kind of safari. There is less danger, of course, although bees and wasps have painful stings, a few insects can

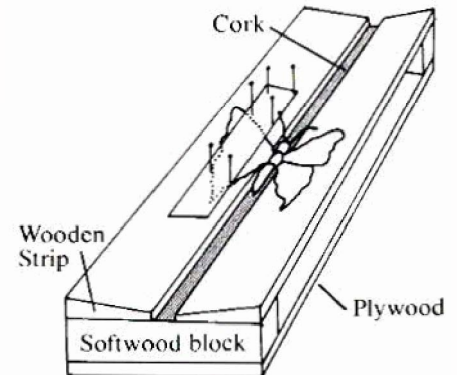

Figure 14. An insect spreading board with construction details.

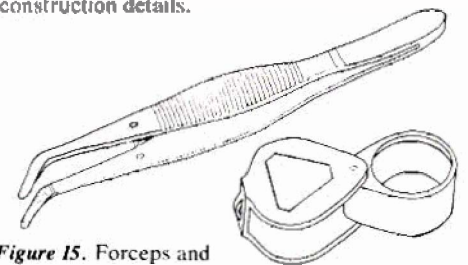

Figure 15. Forceps and hand lens.

Animals other than insects

250,000

Plants of the world

1,000,000

The world's insects

Figure 16. More than half of the living things of the world are insects.

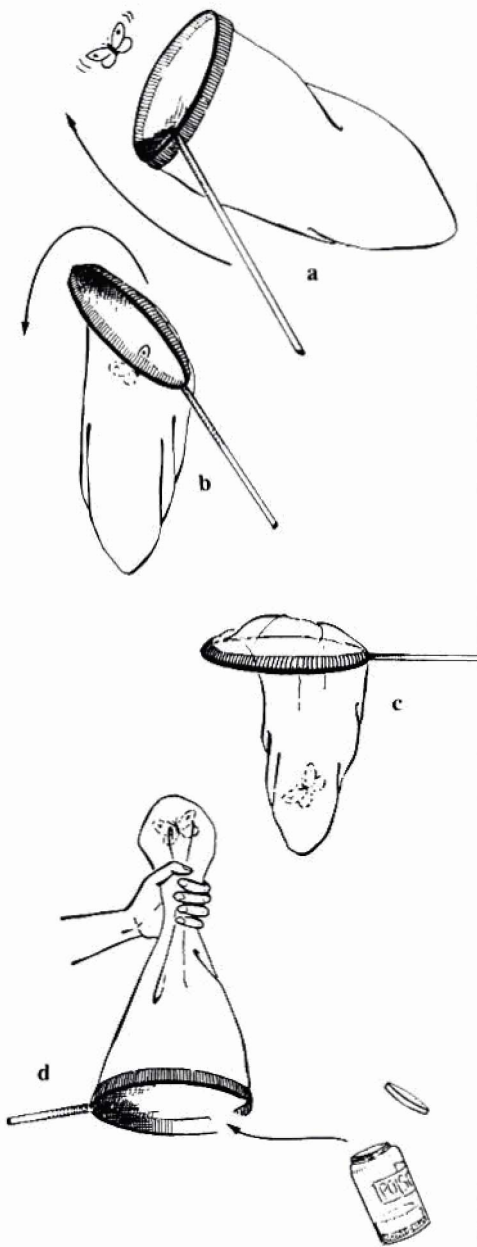

**Figure 17.** The sequence in catching a butterfly with an insect net. (a) Sweep into net. (b) Turn net. (c) Let bag hang over hoop. (d) Grasp net near middle and insert killing bottle.

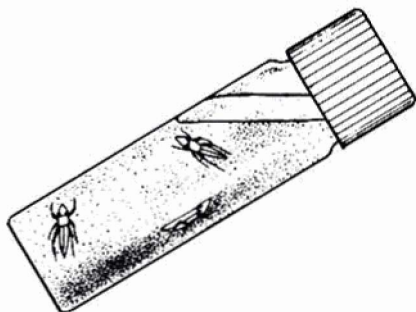

**Figure 18.** Minute and soft-bodied insects such as aphids and caterpillars should be preserved in alcohol and kept in a vial with a tight-fitting lid.

bite or pierce the skin, and a few caterpillars have stinging hairs. Reasonable caution should be used in catching and handling insects. Boys and girls who are allergic to bee venom should not collect bees and wasps.

How you catch insects depends on where they live. Those that live on weeds, bushes, or small trees can be captured with a sweep net. This net is used to literally beat the bushes. Swing it through the weeds and brush with a vigorous motion holding it so that the vegetation always passes around the face of the open bag. When an active insect is caught certain precautions must be used to prevent it from escaping before it can be transferred to the killing jar. The safest method is to fold the net over the ring, with the insect in the bottom of the net (Figure 17). To collect insects in trees, spread a painter's drop cloth under some branches and shake the branches or the tree. Many insects will drop to the cloth, and if you are quick you can catch them before they run or fly away.

Here are areas where you will find certain types of insects:

- Under boards and rocks — ants, crickets, beetles, termites.
- In or around streams, ponds, lakes — mayflies, dragonflies, damselflies, stoneflies, caddisflies, aquatic beetles.
- Under loose bark, in logs, and stumps — termites, ants, bark beetles, tiger beetles, wood borers, etc.
- On crops and ornamental plants — grasshoppers, butterflies, beetles, flies, aphids, leafhoppers, spittlebugs, plant bugs, thrips, bees, and wasps.
- In the air — butterflies, flies, bees, wasps, moths, beetles, leafhoppers, grasshoppers.
- Cellars and basements — crickets, beetles, ants, bristletails.
- On animals and poultry — fleas, sucking lice, biting lice, flies; or in manure piles — flies and beetles.
- In clothes, furniture, stored foods — clothes moths, carpet beetles, flour beetles and moths, and bean weevils.
- Around lights — moths, beetles, true bugs, praying mantids, mosquitoes, some wasps.

- In houses — crickets, beetles, ants, flies, mosquitoes, moths, termites, silverfish.

## How to Mount and Preserve Specimens

Most adult insects in collections are mounted on pins and put in display cases, or they are placed in Riker mounts. Medium-sized or large insects such as bees, flies, moths, grasshoppers, and many beetles should be pinned vertically through the body (Figure 19a). Many small insects such as leafhoppers, should be glued to card points.

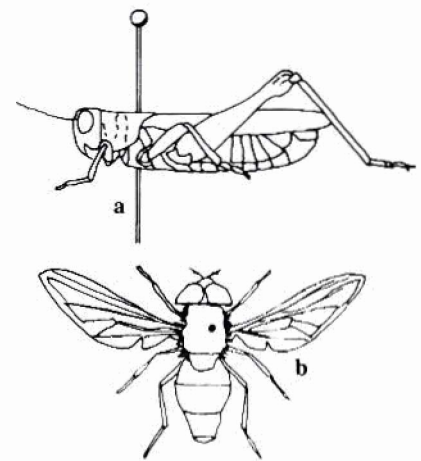

**Figure 19.** Methods of pinning insects. (a) A pinned grasshopper specimen in lateral view. The black spot in the other figures shows the location of the pin in the case of (b) flies, (c) bugs, (d) grasshoppers and (e) beetles (Courtesy Illinois Natural History Survey).

Soft-bodied insects such as aphids, thrips, lice, termites, silverfish, springtails, and some stoneflies cannot be mounted on pins. They can be preserved in small, tightly stoppered vials of 70–75 percent grain alcohol or rubbing alcohol (Figure 18). The vials can then be held in place in the insect box with pins. Larvae of beetles and butterflies also have soft bodies and should be killed by immersing in boiling water for one to five minutes, depending on their size; then they should be placed in the

alcohol solution. The boiling water destroys the bacteria and enzymes and prevents the larvae from turning black.

### Pinning Various Orders of Insects

The correct placement of the pin in the insect depends on the order to which the insect belongs (Figure 18).

- Grasshoppers, katydids, treehoppers, crickets and leafhoppers are pinned through the back part of the thorax to the right of the middle.

- Beetles are pinned through the right wing cover near the front end.

- Bees, wasps and flies are pinned through the thorax near the base of

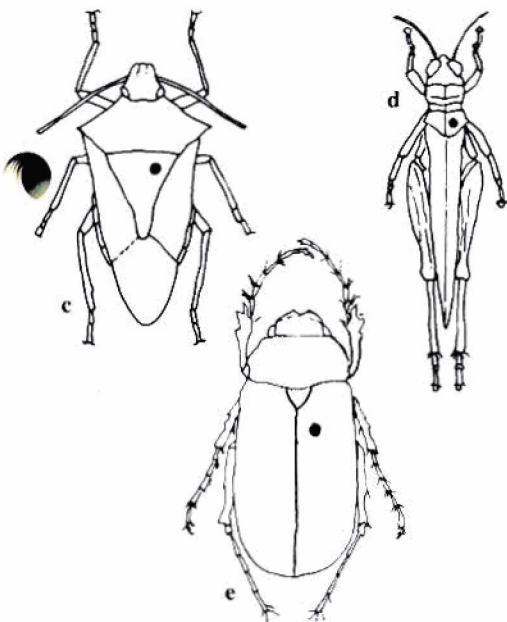

the front wings and slightly to the right of or in the middle of the thorax.

- Moths, butterflies, and dragonflies are pinned through the mid-line of the thorax between the front wings (Figure 20).

- The "true bugs," insects belonging to the order Hemiptera, are pinned through the scutellum (the small triangle on the back) to the right of the imaginary midline.

After the insect has been pinned, its height on the pin must be adjusted (Figure 21). When a pinning block is

used, this adjustment is easily made. On a "step pinning block" use the bottom step. Place the head of the pin in the hole and press it to the bottom. Adjust the insect, already on a pin, so that its back touches the step. The insect should now be about  $\frac{3}{8}$ " (.9 cm) from the head of the pin. This space provides enough room to grasp the pin without touching the insect.

Before the insect is allowed to dry, the legs and antennae should be arranged so they are visible. Insects with long legs or heavy bodies that tend to droop can be supported by placing a piece of stiff paper on the pin beneath them until they are dry.

Insects that are too small to be pinned may be mounted on a "point." A point is a triangle made from a stiff card, about  $\frac{3}{8}$ " (.9 cm) high at the apex and  $\frac{1}{8}$ " (.3 cm) wide at the base. The insect pin is run through the widest end of the point and the point is bent over and a drop of rubber cement or any quick-drying glue is placed on the tip of the point (never on the insect) and the insect is placed on the glued tip (Figure 22). The point is inserted between the legs so that the glued-on point is on the right side of the thorax.

### Spreading the Wings of Various Insects

One of the most difficult tasks for young collectors to learn is the proper setting of moth and butterfly wings. It requires practice and patience. The beginner should start practicing with grasshoppers because their wings are relatively strong and less likely to tear. The exact procedure is not important as long as the wings and other body parts are not damaged and the wings are given the proper position. The back margin of the forewings must be at right angles to the body and the hind wings' anterior margin must be barely hidden beneath the forewing.

A good procedure for spreading the wings follows. First, pin the insect through the thorax (Figure 23). Next place it in the groove of the spreading board. The wings, where they arise from the thorax, should be level with

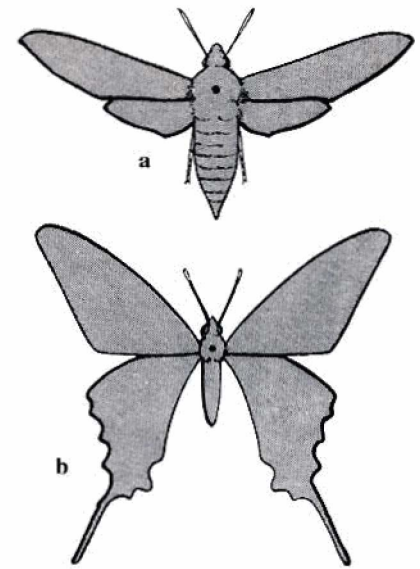

Figure 20. Method of pinning *Lepidoptera*. These insects are pinned through the center of the thorax in both (a) moth and (b) butterfly (Courtesy Illinois Natural History Survey).

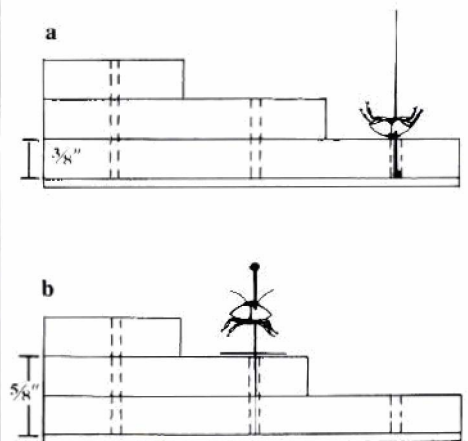

Figure 21. Using the pinning block. (a) Adjusting the height of insect on pin. (b) Adjusting height of label.

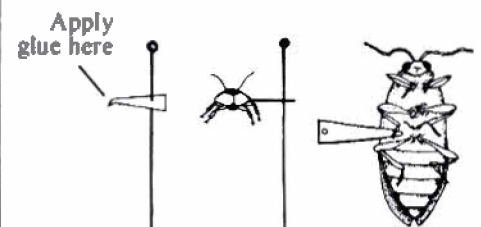

Figure 22. Glue insect on card point.

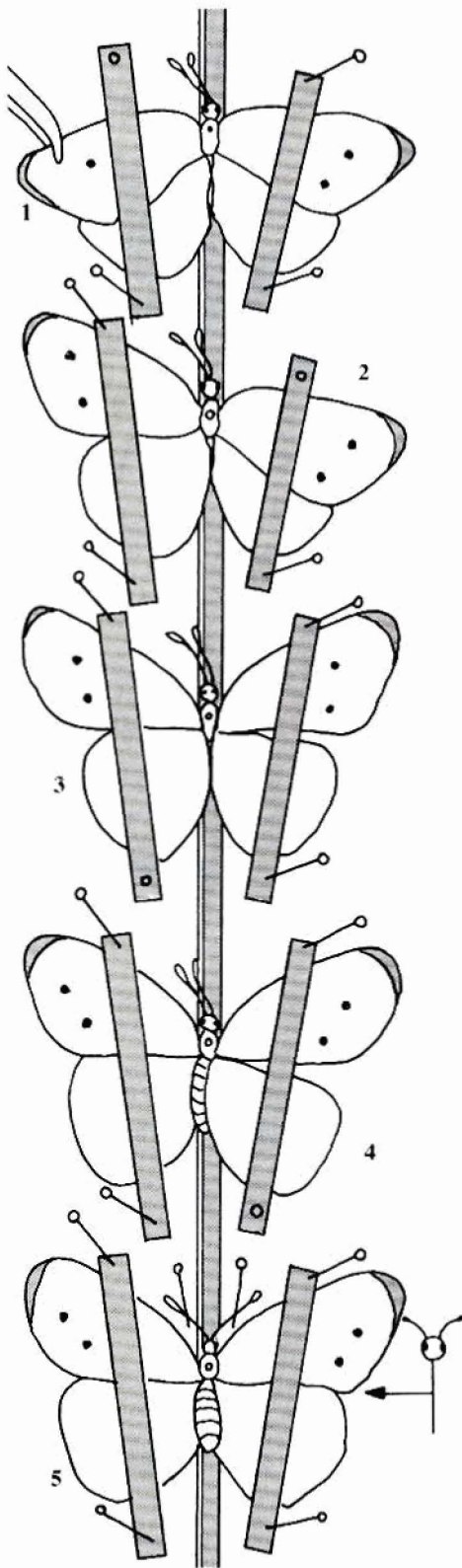

Figure 23. Steps in spreading the wings of butterflies and moths.

the horizontal surface of the board.

Using dressmaker's pins, fasten narrow strips of wax paper over the wings to hold them in a horizontal position. Starting with the left side, loosen the wax paper strip enough to allow the front wing to be moved forward. Grasp the wing by the heavy vein that follows the front margin with forceps (tweezers) and pull the wing forward till the back margin is at a right angle to the body. Tighten the wax paper strip and replace the dressmaker pin. Follow the same procedure for the right side. Next, maneuver the hind wing into position with a pin from near the base of the wing. Loosen wax paper strip as necessary, but not enough to allow the front wing to go back to its original position. Do not put pins in the wings if it can be avoided. After the wings have been positioned, adjust the antennae and abdomen as shown in the illustration. You may spread the wings of several insects before placing the spreading board, with specimens, aside to dry. Drying requires about a week but varies with the size of the insect. If the wings of insects tend to droop when removed from the spreading board, they have not been allowed enough drying time. See Figure 23 for steps in spreading Lepidoptera wings.

All butterflies and moths should have the wings spread. Dragonflies and damselflies may also have wings spread, and the Orthoptera, such as grasshoppers and mantids, should have only left wings spread. The latter two are optional. You may also find it interesting to spread the wings of insects in other orders.

## Identifying Specimens

In unit A, members are required to identify their specimens only as far as order. In the advanced units, it becomes more important to know the complete biological classification of each specimen.

Classification is a means of identification. In all societies individuals are classified in numerous ways. The grading system in public schools is a classification, telephone numbers are classifications, and addresses are classifications.

Let's use a person's mailing address to find how his postal classification compares with an insect's biological classification. The fictitious address will be:

Postal Identification		Biological Identification	
New York	State — Class	Insecta	
Schenectady	City — Order	Hymenoptera	
Maple Street	Street — Family	Aphidae	
Smith	Surname — Genus	Apis	
Daniel	Given name — Species	mellifera	

When a letter carrier sorts personal mail, he or she reads the address from the bottom to top, looking first for the state. Knowing the state, New York, he or she has thus eliminated all the individuals in the other 49 states. But still one individual must be separated from the rest of New York State's 17 million people. Finding the city reduces the possibility to 82,000 — the population of Schenectady. The street and number have reduced the number of possibilities to those living in the house at 234 Maple Street. The Smiths, a family of four, live there. Alice, Barbara, Charles, and Daniel. Using the postal classification, the letter carrier has now separated out the one individual from the total U.S. population of approximately 193 million people.

Similarly, an entomologist classifies insects by the process of elimination, ending with the identity of one species.

When an entomologist classifies an animal, he or she must get clues from its structure and give it an "address." The terms of the scientific "address" are *class*, *order*, *family*, *genus*,

species. Starting with structural characteristics that place the specimen in the class Insecta — then, with 26 orders to choose from, the entomologist finds the characteristics that are peculiar to the order Hymenoptera. The same procedure is followed until the species is identified and the insect classified *Apis mellifera* (the honeybee), one of the nearly 17 million kinds of insects known to be found in New York State. Note also, that the person's name and the insect's name are made up of two elements: a surname and a given name — a genus and species.

From structural characteristics and others, the biologist sorts out common features and prepares a classifying tool called a key. At each step the key requires making a choice between two contrasting characters. In the following key your first decision is: Is the insect wingless (Figure 24a) or does it have wings (Figure 24b)? Follow the key as you would a road map. In most instances you will come to a correct identification, but don't be too surprised if you don't. No key is perfect, for there are always specimens that defy the generalizations that make up the key. This key on pages 12 and 13 applies only to adult insects.

A quick guide to identification of some insect orders.

**Orthoptera** — (orthos means straight, ptera indicates wings) straight wings—crickets, grasshoppers, katydids, cockroaches, walking sticks. These insects are rather straight in appearance, and they have wings.

**Hemiptera** — (hemi means half; ptera — wings) half wings — the front wings are leathery at the base, membranous at the apex. Water bugs, stink bugs, bed bugs, assassin bugs.

**Homoptera** — (homo means the same, ptera — wings) wings fold rooflike over body when at rest, front wings longer than hind. Aphids, cicadas, leafhoppers, treehoppers, and scale insects.

**Coleoptera** — (coleo — sheathlike,

ptera — wings) front wings hard, sheathlike, often fitting over body forming a hard case. Beetles: lady beetles, potato beetle, leaf beetles, carpet beetles.

**Lepidoptera** — (lepis — scalelike, ptera — wings) butterflies, moths, and skippers.

**Diptera** — (di — two, ptera — wings) flies, mosquitoes, gnats.

**Hymenoptera** — (hymen — membranous, ptera—wings) wings membranous—wasps, ants, bees, and sawflies.

**Odonata** — (odon — tusklike) dragonflies, darning needles, damselflies.

**Isoptera** — (iso — equal, ptera — wings) termites.

**Siphonoptera** — (siphon — siphon) siphoning mouthparts: fleas.

**Neuroptera** — (neuro — nerve; ptera — wings) nerve-winged insects—lacewings, antlions.

**Trichoptera** — (tricho — hair, ptera — wings) wings covered with fine hairs—caddisflies

**Ephemeroptera** — (ephemeros — lasting but one day; ptera — wings) mayflies: the adults are very short lived, the imago lasts only part of a day.

**Collembola** — (embola — to throw) springtails throw themselves through the air.

## Labeling Specimens

The scientific value of an insect specimen depends largely on the accuracy and completeness of the collection data attached to it. The most important facts on the label are the place of capture and the date, but the specimen's value will be greater if the label includes the collector's name (Figure 25). Additional labels may include information on the host on which the insect fed or more details of how it was captured. For our purposes, a second label should be included with each specimen giving either an insect number (Figure 25) (first- and second-year collections) or a family, genus and species label. The common name may be included but,

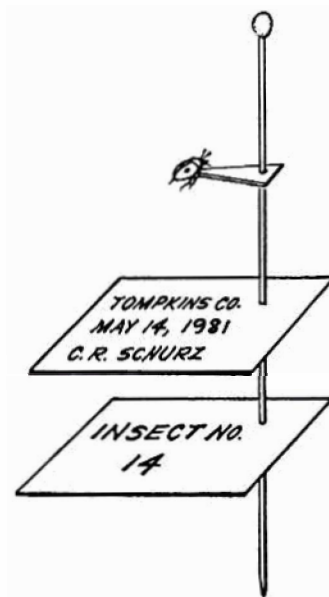

Figure 25. All pinned specimens in a 4-H collection should be labeled as illustrated. The first label contains the location, date, and name of person that collected the specimen. The second label is for the insect number, used for reference to your insect record chart. For third year and older members, the second label may contain family name, genus, and species.

# Wingless Insects

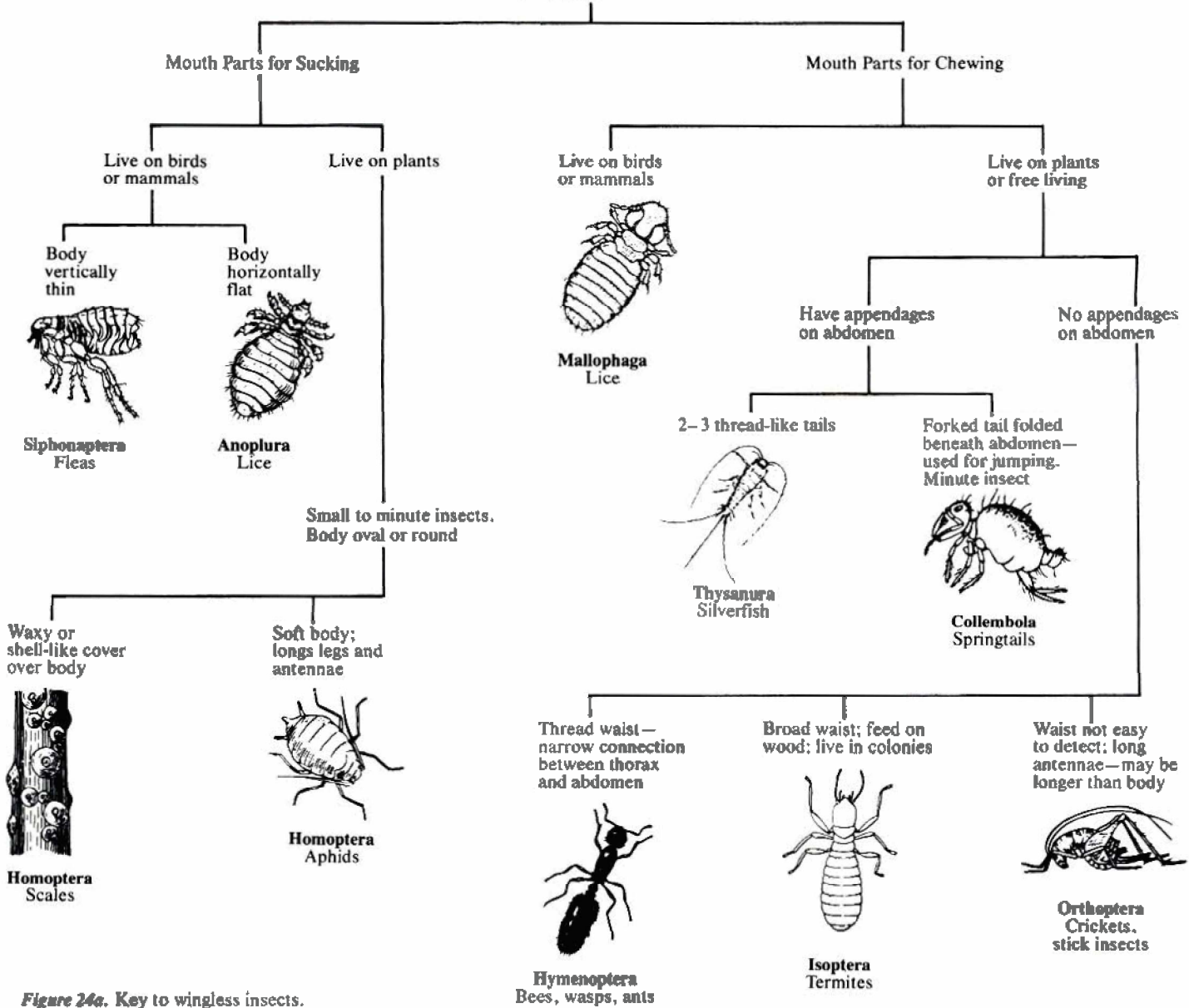
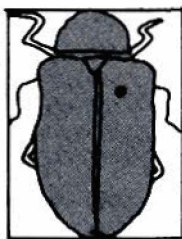

Figure 24a. Key to wingless insects.



• Dogbane Beetle •

Figure 26. For your 4-H collection exhibit, the common name should be pinned on a separate label below the specimen.

for display purposes, should be on a separate label, pinned in the display box below, but separate from, the insect (Figure 26).

The Cornell and Harvard museums are the two largest university collections of insects in North America. The Cornell collection has more than four million specimens from all parts of the world representing about a half million species.

## Preparing Insects for Display

Insects that have been collected, labeled, and identified to the order name should be arranged in display cases or Riker mounts. In a display case, line up the insects behind the appropriate order labels, which are pinned to the bottom of the box. Use the labels supplied with the project record forms or neatly print your own. (Figure 27, p. 14) No definite sequence of orders is required. The member should assemble the collection in a manner that displays it most effectively within the above guidelines. In Riker mount arrangements, identification labels can be in

# Winged Insects

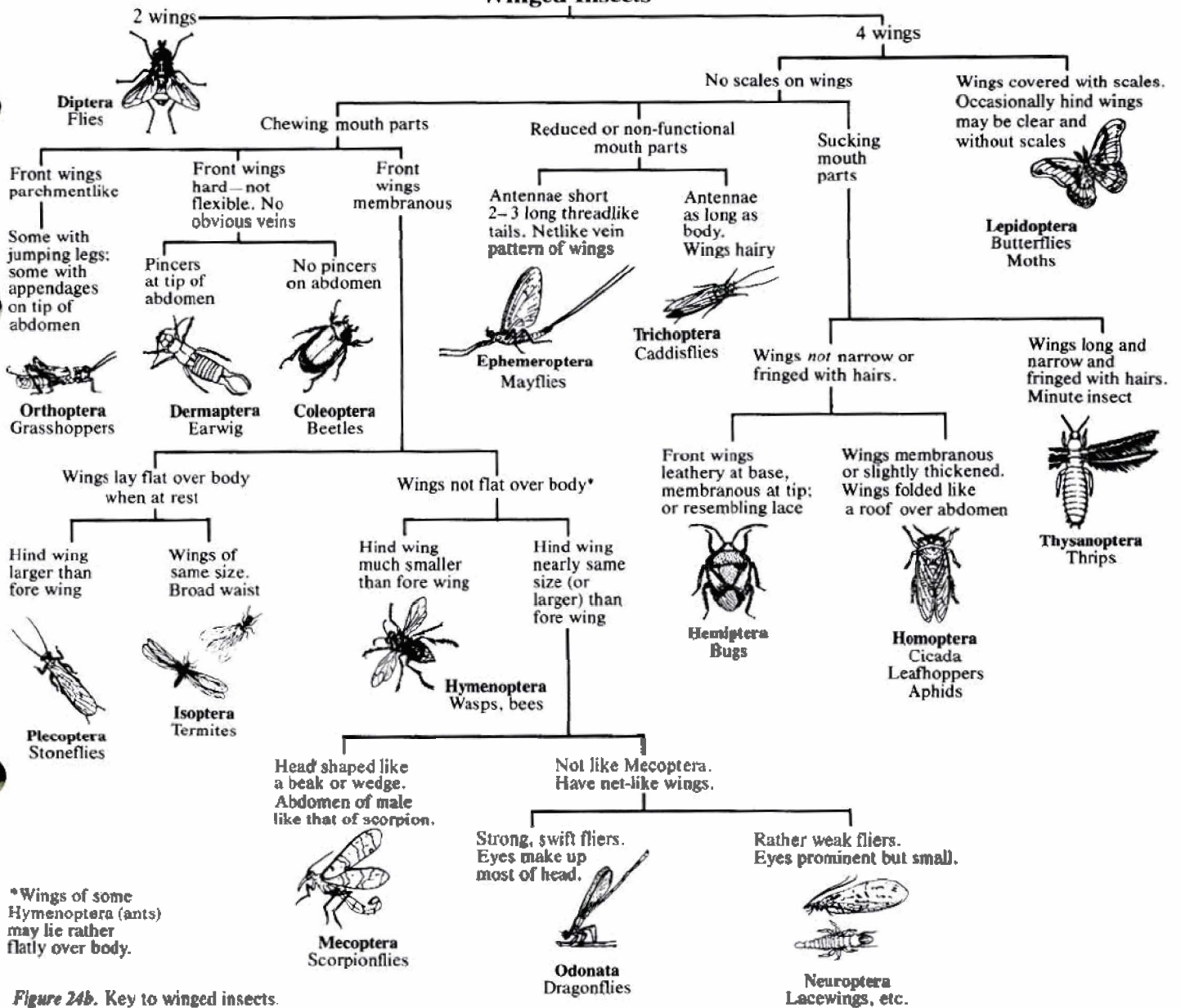

Figure 24b. Key to winged insects.

any location where they do not detract from the specimens.

The insect display box and Riker mount should have the owner's name, address, and county. The first-year fair exhibits must include a minimum of 20 specimens representing five insect orders; the second year, a minimum of 40 specimens representing nine insect orders. Both exhibits must contain at least 20 specimens collected during the current year. Third-year exhibits must include a minimum of 60 specimens representing 12 insect orders; 30 specimens must have been collected during the year. Check your fair premium book yearly for a more complete description of collection requirements.

Remember, you will be graded on accuracy of identification, pinning, neatness, and condition of specimens (no broken or missing parts).

## Storing Your Collection

Did you know there are insects that feed on dried insects? There are several species that can quickly destroy an insect collection. Three or four large moth crystals (paradichlorobenzene or PDB) or moth balls (naphtha) fastened in the corner of a storage or exhibit box will keep out Dermestid beetles and other museum pests. Heat the head of a common pin and force it into the moth ball. The hot pin will melt the crystal and upon



Figure 27. A blue ribbon collection that was exhibited at the New York State Fair.



Figure 28. A moth ball attached to a dressmaker's pin. A hot pin can be forced into a mothball. When the pin cools, it will be firmly attached.

cooling will be firmly attached to it (Figure 28). Loose moth balls or crystals in the bottom of an exhibit case can damage the fragile specimens. A piece of Vapona strip (No-Pest Strip) about 1" x 1" (2.5 cm x 2.5 cm) also may be used in the box to keep out pests.

### Demonstration Suggestions

Members taking the entomology project are expected to give demonstrations before their club. A demonstration is simply showing and telling how to do something. Some suggested topics are:

- How to make an insect killing jar.
- How to make a spreading board.
- How to make a collecting net.
- How to pin or mount an insect.
- How to spread the wings of a butterfly.
- How to tell the difference between an insect and other arthropods (spiders, millipedes).

- How to identify an insect.
- Ways to preserve the life-cycle stages of an insect.

Choose your own subject. Try to think of an interesting title. Prepare posters, illustrations, and equipment that will make your subject easier to understand. Help will be available from club leaders and others who may have assisted in teaching the project.

### References

- Handbook of the Insect World*. Hercules Powder Company. 1956. Available from your local Cooperative Extension 4-H agent or National 4-H Council.
- Insects — The Yearbook of Agriculture*. 1952. USDA. U.S. Government Printing Office, Washington, D.C. 20402.
- A Field Guide to the Insects of America North of Mexico*. D. J. Borror and R. E. White. Boston, MA: Houghton Mifflin, 1970.
- How to Know the Insects*. 3rd ed. R. G. Bland and J. E. Jaques. Dubuque, IA: William C. Brown Company, 1978.
- How to Know the Beetles*. H. E. Jacques. Dubuque, IA: William C. Brown Company, 1951.
- Butterflies and Moths (Golden Guide Series)*. R. Mitchell and H. S. Zim. Racine, WI: Western Publishing Company, 1964.
- Insects — A Guide to Familiar American Insects*. H. S. Zim and C. Cottam. New York: Simon and Schuster, 1951.
- The Moth Book* (rev. ed.). W. J. Holland; ed. by A. E. Brower. Dover Publications, Inc., 1968.
- Storing and Labelling an Insect Collection*. R. Dirig. 4-H Members' Guide M-6-7. Cornell University, Ithaca, NY 14853. 1977.



# Know Your Insects

## Unit B

After a club member has satisfactorily completed a first and second year general collection in Unit A, he or she may make one or several of the collections suggested in Unit B. These specialized collections take more time and effort since they require specific kinds of insects (Figure 29). The member can use the standard exhibit case if the collection lends itself to this kind of display, otherwise he or she should devise a display method complementary to the project. Unit B or C collections that are to be graded should be submitted with a written summary. Some suggested Unit B collections are:

- Flies (*Diptera*) — minimum five families, 20 specimens.
- Bees and wasps (*Hymenoptera*) minimum five families, 20 specimens.
- Butterflies or moths (*Lepidoptera*) minimum five families, 20 specimens.
- Bugs (*Hemiptera*) minimum five families, 20 specimens.
- Grasshoppers, crickets, roaches and other *Orthoptera*, minimum five families, 20 specimens.
- Beetles (*Coleoptera*) minimum five families, 30 specimens.
- Insects that feed on or annoy livestock and pets, including birds — minimum 12 specimens (may include mites and ticks).
- Aquatic insects<sup>1</sup> (insects that spend part of their life cycle in water) — minimum 15 adult specimens representing at least three orders.
- Insects and disease pests of garden vegetables — minimum 25 specimens (see NYS 4-H Members' Guide M-11-3, *Insect and Disease Control on Vegetables*).



Figure 29. These visitors observe living aquatic insects from a 4-H club display.

- Insects that feed on flowers, shrubs, and trees — minimum 25 specimens.
- Leaves mined by insects<sup>2</sup> — minimum 10 specimens.
- Insect galls — minimum 15 specimens.
- Household and stored-product insects — minimum 10 specimens.
- Wasps and their nests — minimum of five specimens.
- Insects found on specific plants such as oak trees, evergreen trees, roses, and milkweed; minimum 10 insects per plant, with a leaf and twig from host plant.
- Immature insects<sup>1</sup> — minimum 12 specimens in five orders.
- Predatory insects — minimum 12 specimens in five orders.

<sup>1</sup>Mimeographed guide and reference list is available from your 4-H agent.  
<sup>2</sup>Leaves must be dried in a plant press and attached to standard size sheets of mounting paper.

## References

- How to Know the Immature Insects*. H. F. Chu. Dubuque, IA: William C. Brown Company, 1949.
- How to Know the Beetles*. H. E. Jacques. Dubuque, IA: William C. Brown Company, 1951.
- The Moth Book*. (rev. ed.). W. J. Holland; ed. by A. E. Bower. Dover Publications, Inc., 1968.

# Know Your Insects

---

## Unit C

Advanced work in entomology includes the following projects or activities. For some of the subjects, additional printed instructions and references are available from your 4-H agent.

---

### Insect Rearing

The proper food, light, and temperature are key factors in rearing insects. If you want to study the life history of an insect, keep the young in a box and supply them with the food they normally eat, the light and temperature of their natural habitat. Many different kinds of moths and butterflies have been reared in wide-mouth jars with cheesecloth tied over the open end. Rectangular plastic refrigerator dishes also make excellent rearing containers. Insects living in ponds may be kept in an aquarium. If you want to breed insects, you will need screened cages to hold the adults. Large cages are necessary for some insects, but to get started make one that's about one cubic foot. Rearing honeybees should not be attempted without the help of an experienced beekeeper.

The 4-H Members' Guide M-6-6, *Growing Moths* describes methods for rearing many native moths. Some biological supply companies have leaflets that explain rearing procedures for specific insects.

Members who complete rearing projects should preserve all stages of each species and display them in Riker mounts. A record form (a written summary) also should be completed.

---

### Insect Control

In this part of the entomology project you will carefully study some pest insects so that you can learn how to control them. You will need to know how the pests cause injury and at what stage they cause damage.

Good subjects are flower garden and lawn insects, dog or cat pests, household pests, fruit tree pests, and vegetable garden pests. Before using control measures on the insects you have selected, estimate or count the numbers of the insects in the area where you will work. After applying control measures, make inspections at regular intervals, estimating or counting the number of insects pres-

ent each time. Keep a record of your observations.

For information about control methods and insecticides consult your Cooperative Extension agent. He or she can provide you with leaflets that give detailed recommendations.

Insecticides are chemicals that kill insects. The common ones such as Sevin, pyrethrum, methoxychlor, and malathion may safely be used by boys and girls who are 12 years of age or older.

The insecticide may be available as a dust, wettable powder, or liquid solution (emulsion). The dust is applied without further dilution. Wettable powders and liquid solutions are mixed with water. Before using any insecticide, READ THE LABEL on the container. This gives directions for application based on scientific research concerning effectiveness of the chemical and safety. After working with insecticide wash thoroughly any part of your body that was exposed. Keep all bottles and packages containing insecticides in their original containers and away from young children and pets. If there is spray material left in your sprayer, pour it on the ground in an out-of-the-way corner of your lot. Never pour leftover insecticide in a stream or sewer. It may kill fish or pollute water.

Additional information on vegetable garden pests and their control may be found in 4-H Members' Guide M-11-3, *Insect and Disease Control on Vegetables*.

## Trapping Insects

Insects can be trapped using baits and lights. Collections should be made to show what kinds of insects are caught in various traps (light trap, underwater light trap, or a simple bait trap). A record should be kept of the lure used, that is, the kind of bait or light. A bait mixture of malt and molasses attracts many kinds of insects. Any food that is beginning to decay or ferment will attract insects. In light traps use several kinds of

light sources such as blacklight (ultraviolet), fluorescent, and incandescent white and yellow light. A separate collection should be made for each kind of light used.

Baits attractive to insects can be used to make field trips or camp collecting activities more interesting. Make a bait with five tablespoonfuls of molasses, half-pint of soured fruit juice and a teaspoonful of geraniol. (Geraniol is the chemical used in Japanese beetle traps, frequently available in garden supply stores). Daub this mixture on tree trunks, rocks, boards, and the like with a paint brush.

## Wing Collections in 2" x 2" Slide Mounts

Insect wings have important features useful for identification. Each order has a characteristic wing shape and venation. Venation refers to the system or arrangement of veins. Some groups can be identified by color patterns and wing shape, however, venation usually provides the most reliable identification.

To learn about wing venation you must first get to know the names of the veins and how to interpret vein arrangement. Study the wing descriptions and vein interpretations in *An Introduction to the Study of Insects* by Borror *et al.* listed in the References. Wing characteristics are especially useful in the identification of Odonata, Lepidoptera, Hymenoptera, Diptera, and Tricoptera.

The following supplies and equipment will be needed: 2" x 2" (5 cm x 5 cm) glass slides, slide binding tape, slide masks (available from photographic stores), small camel's hair brush, alcohol, white distilled vinegar, bleach, and forceps.

Hold the insect in a head-up and feet-away position and remove the right wings with a pair of fine-pointed forceps. On four-winged insects there may be wing-coupling structures such as bristles or hooks. Be careful not to break them.

Folded wings, such as those on grasshoppers and beetles, must be

spread open. To spread the folded wing, lay it on a glass slide in its normal position. Dip a camel's hair brush into alcohol and transfer a drop to the wing. With the brush and the round head of an insect pin, gently move the wing into its open position. Place a slide mask around the wing (labeling data should be put on the mask), put on the slide cover, and bind with tape (Figure 30).

When wings are  $\frac{1}{2}$ " (1.3 cm) or less in length it is better not to use a mask because the mask may be thicker than the wings and the wings may slip or curl after the slide is bound. In this case the label can be put on a small slip of paper and taped to the outside of the slide.

It is necessary to bleach the wings of most Lepidoptera before the veins can be seen. A method of bleaching is:

Use three shallow saucers — one containing 95 percent alcohol, one containing distilled white vinegar, and one containing a commercial bleach (such as Chlorox). Fill a fourth deeper dish with water.

First dip the wings in alcohol for a few seconds to wet them, then dip them in vinegar for a few seconds. Place the wings in Chlorox and leave them until the color is removed. This requires a few minutes. Rinse in water to remove the excess bleach. While the wings are still wet, lay them on the slide in their proper position. Place several droplets of water on the slide so that the wings can be floated into place. Excess water can be drawn off with a blotter. Allow the wings to dry, then complete the slide mount as previously described.

The wings are now ready to project on a screen as you would any 2" x 2" (5 cm x 5 cm) photographic slide. Two projectors can be used to compare wing slides of different families, genera, and species.

A minimum of six slides should be submitted to your 4-H agent for display at the State Exposition.

## Embedding Insects in Plastic

Many hobby or craft shops as well as several companies will carry the equipment needed for embedding insects. You will need a clear, highly refined resin and the catalyst to go with it. The process you will be following will be to pour one layer of "catalyzed" plastic into a glass mold where it is allowed to harden. The insect is placed with its feet up in the center. Then a second layer is poured on the top to cover the insect and the casting is set aside to harden.

When embedding it is important that specimens be dried when adults are used. For larvae, a chemical method using alcohol is followed to remove moisture. Most manufacturing companies provide a direction sheet with the plastic resin and catalyst. Follow directions carefully for best results. For exhibit, display specimens representing nine insect orders (Figure 31).

## Photographing Insects

Taking a close-up picture of a live insect requires skill, patience, and proper equipment. The equipment may be made or purchased. Your photo supply dealer can suggest some "close-up" equipment.

For exhibit purposes, display a minimum of five 2" x 2" (5 cm x 5 cm) slides. They may be of five different kinds of insects or a series of pictures showing different views and stages of the same insect. If there is a 4-H photography club in your community, discuss your interests with the club leader.

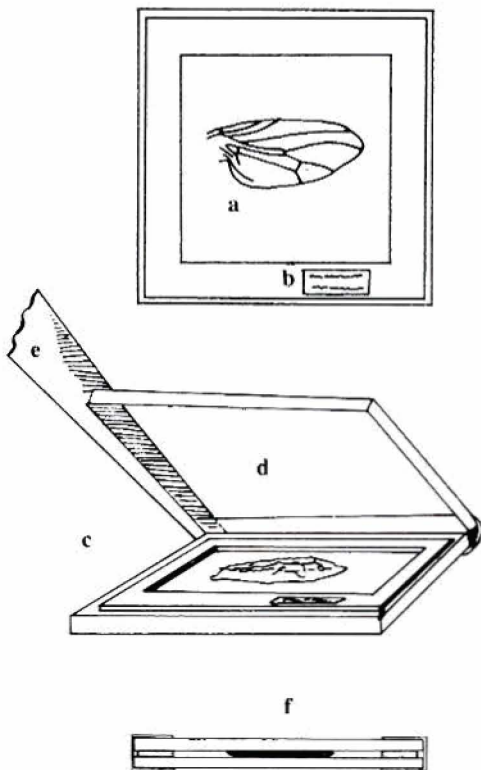

**Figure 30.** The steps for making 2" x 2" (5 cm x 5 cm) glass slide mounts of insect wings. (a) An insect wing as seen inside a completed slide, (b) Label attached to the mask, (c) Paper framing mask, (d) 2" (5 cm) square glass plate, (e) binding tape, (f) a cut-away view.

## Correspondence Clubs for Trading Insect Specimens

A club called Teen International Entomology Group (TIEG) now has its headquarters at Michigan State University. The group has members from most states and from a number of foreign countries (Figure 32). It brings together by postal service youth with similar interests. In their letters members discuss their problems in collecting, insect rearing, and the like, and arrange for trading and expanding their insect collections. To become a member you must have an interest in entomology, be willing to correspond and help other teen entomologists, and in some cases be willing to give or to exchange dried insects. There is a small fee for dues. The TIEG group publishes *TIEG Magazine* as well as a more frequent listing of members' activities, short articles, and exchange lists. For further information contact:

TIEG Editor  
Department of Entomology  
Michigan State University  
East Lansing, MI 48824  
USA

Collections assembled by trading may be exhibited and compete for awards under an advanced project category. All specimens should be properly labeled with the place of origin, collector if known, date collected, and what the specimen is.

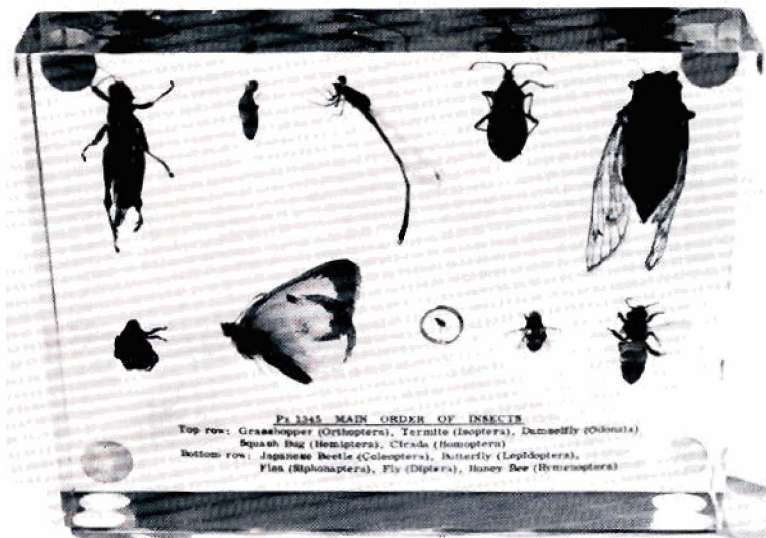
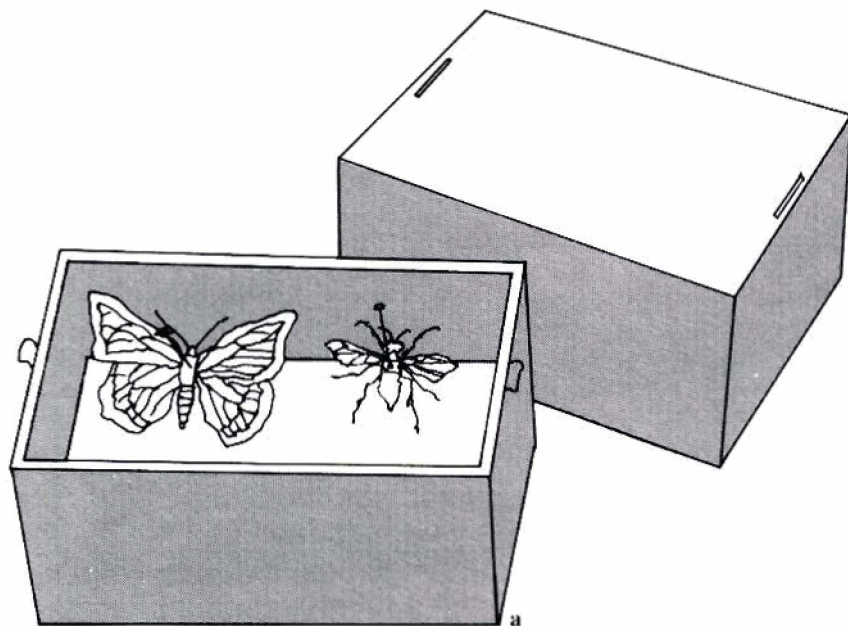

Figure 31. The main orders of insects embedded in plastic.



Figure 32. A Teen International Entomology Group's exhibit at State Exposition.



## How to Ship Insect Specimens

Dried insects are very fragile, but they may be safely sent through the mails or by express if they are properly wrapped. Use a shipping box like the one in Figure 33. These can be purchased from a biological supply house. Set the mounting pins firmly in the composition floor of the box. Support the spread wings of insects with blocks of plastic foam firmly attached to the bottom of the box. Put the lid in place, then put the shipping box on a loose bed of shredded paper in a corrugated paper container. Do not pack the shredded paper tightly or the cushioning effect will be lost. When the corrugated box is sealed, the insects are ready for mailing.

Another popular method of storing dried, unmounted specimens and shipping them is "papered," as in Figure 34. If papered properly even fragile insects are protected. Collection data should be written directly on the envelope or on a separate piece of paper and slipped inside with the specimen.

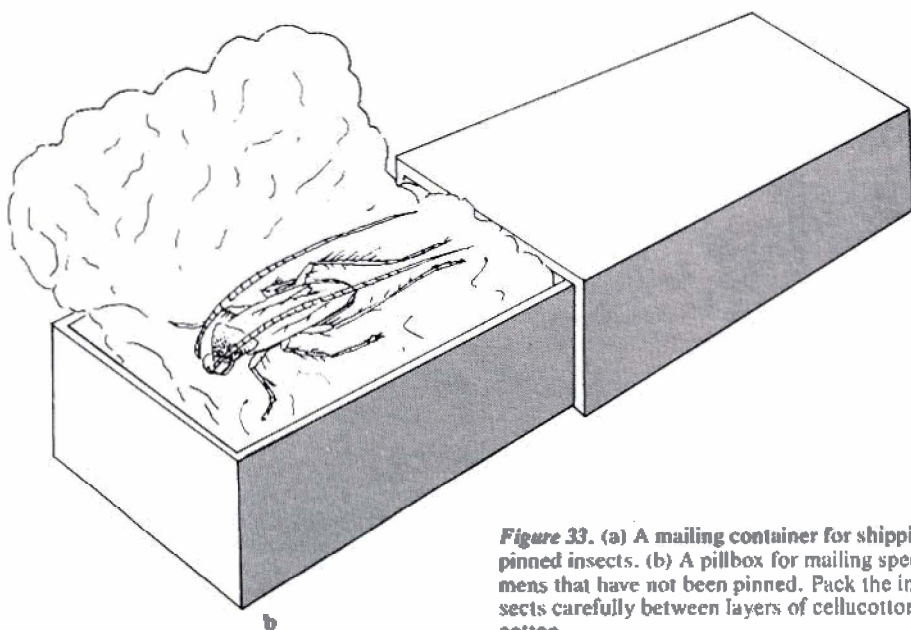

**Figure 33.** (a) A mailing container for shipping pinned insects. (b) A pillbox for mailing specimens that have not been pinned. Pack the insects carefully between layers of cellucotton or cotton.

## References

- An Introduction to the Study of Insects*. 4th ed. Ed. by D. J. Borror et al. New York: Holt, Rinehart and Winston, 1976.
- Insect Life and Insect Natural History*. 2nd ed. S. W. Frost. Dover Publications, Inc., 1959.
- Insect Pests* (Golden Guide Series). G. Fichter. Racine, WI: Western Publishing Company, 1966.
- Insect and Disease Control on Vegetables*. C. Klass and S. W. Westcott, 4-H Members' Guide M-11-3. Cornell University, Ithaca, NY, 1980.
- Growing Moths*. R. Dirig. 4-H Members' Guide M-6-6. Cornell University, Ithaca, NY, 1975.
- Moths and How to Rear Them*. P. Villiard. Dover Publications Inc., 1975.

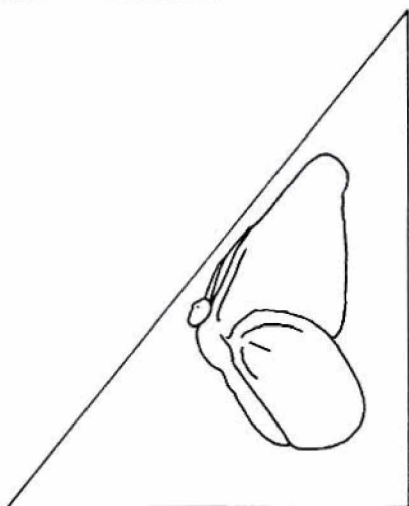
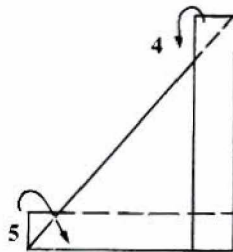
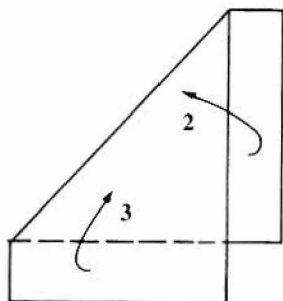
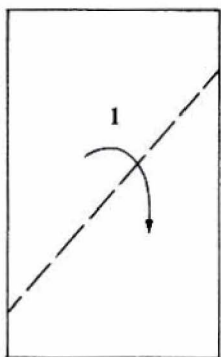

Right

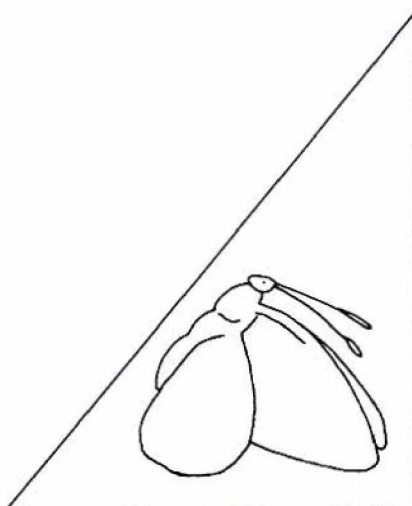

Wrong

**Figure 34.** Papering insects. These illustrations show how to temporarily store unmounted specimens of butterflies, moths, and dragonflies for shipping or until they can be relaxed and mounted. A rectangular piece of paper, of a size suited to the insect it will contain, is folded at numbered points. Make sure insect is in correct position.

Would you like our free catalog of extension publications? It is available from any county Cooperative Extension office in New York State, or write to:

Distribution Center  
7 Research Park  
Cornell University  
Ithaca, NY 14850

Price per copy \$1.50.  
Quantity discount available.

Cooperative Extension, the New York State College of Human Ecology, and the New York State College of Agriculture and Life Sciences, at Cornell University, Ithaca, N. Y., and the U.S. Department of Agriculture, cooperating. In furtherance of Acts of Congress May 8, June 30, 1914, and providing equal opportunities in employment and programs. Lucinda A. Noble, Director.